

BATTERY "FUEL" GAUGE

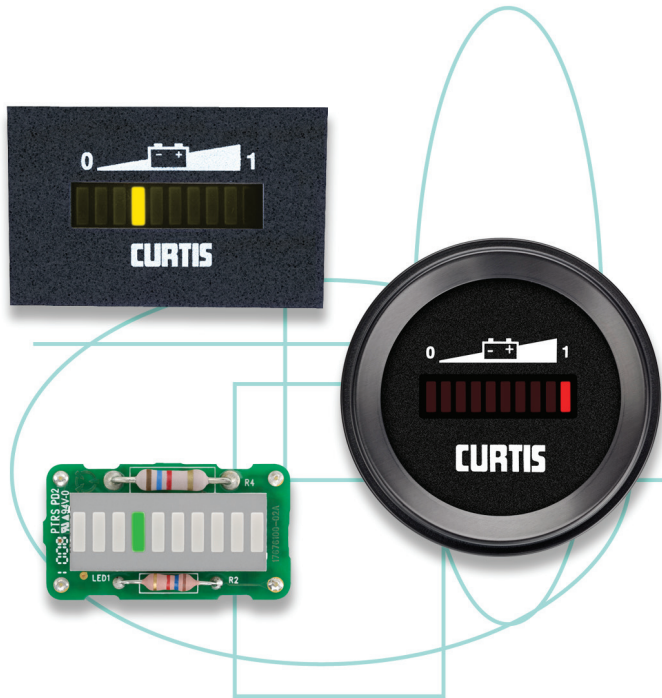

CURTIS

MODEL 906



DESCRIPTION

Model 906 is an inexpensive, one piece, easy to install battery fuel gauge. It is completely solid state and provides a reliable, accurate, and easy to read display of battery state-of-charge. Model 906 is available in six panel mount packages and a printed circuit board mounted module for custom dash panel applications.

APPLICATION

This battery fuel gauge features Curtis patented technology and is ideal for golf cars, commercial cleaning equipment, mobility aids, electric bicycles, electric marine motors, medical devices, and similar equipment.

FEATURES

- All principal circuits are integrated in a single chip for long-life reliability.
- A 10-bar LED displays the state-of-charge successively, bar by bar, from full to empty.
- At 70% depth of discharge, a flashing LED signals an "energy reserve" alert.
- At 80%, alternately flashing LEDs provides an "empty" status warning.
- Model 906 is compact and easily installed in panel cutouts as small as 36.8 X 24.1 mm, with as little as 35 mm behind panel clearance needed, see dimensions of various case styles.
- Recognizes improperly charged battery.
- Keyswitch activated LED display (state-of-charge is monitored as long as 906 is connected to battery).
- Memory allows gauge to recall state-of-charge whenever battery is disconnected.
- Three possible reset methods:
 1. **Open Circuit Reset (OCR):** Upon reconnection of a battery the gauge will reset if it measures 2.09 volts/ cell or higher (example "B" profile) (for units with memory option).
 2. **High Voltage Reset (HVR):** Gauge must measure >2.35 volts per cell for 6 continuous minutes during charging (example "B" profile).
 3. **Charge Tracking Reset (CTR):** Display tracks charge level during opportunity charging (requires gauge to be connected to battery when charging).

OPTIONS

- The Output Signal option causes the voltage on pin 3 to drop from 5 to 0 volts at 80% discharge. It can be used to signal another component or to allow for the disabling of a specified vehicle function, insuring against abusive deep discharge conditions. The Output Signal can also be used to drive the Curtis 1178 Relay Module.
- Special models and custom panels are available.

SPECIFICATIONS

System Voltages: 12V, 24V, 36V, 48V

Operating voltage: +/-25% of nominal voltage

Operating temperature: -40°C to +85°C

Storage temperature: -50°C to +90°C

Shock & Vibration: Meets SAE J 1378

MODEL 906

DIMENSIONS mm continued

Case Style Z

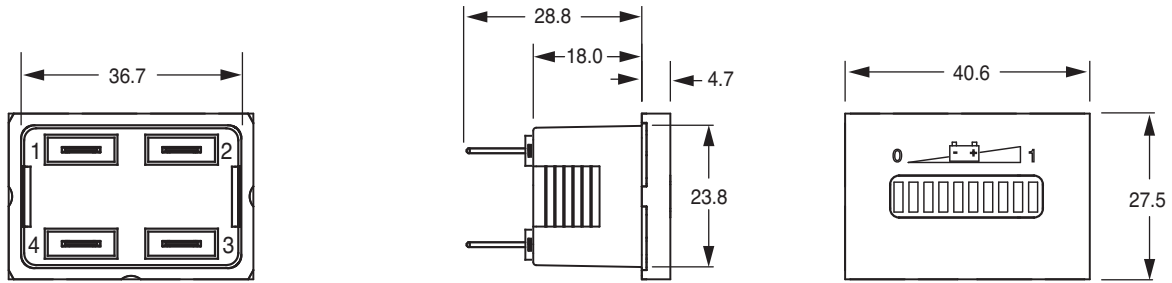

NOTE: 1/4" fast on spade terminals.

Module P

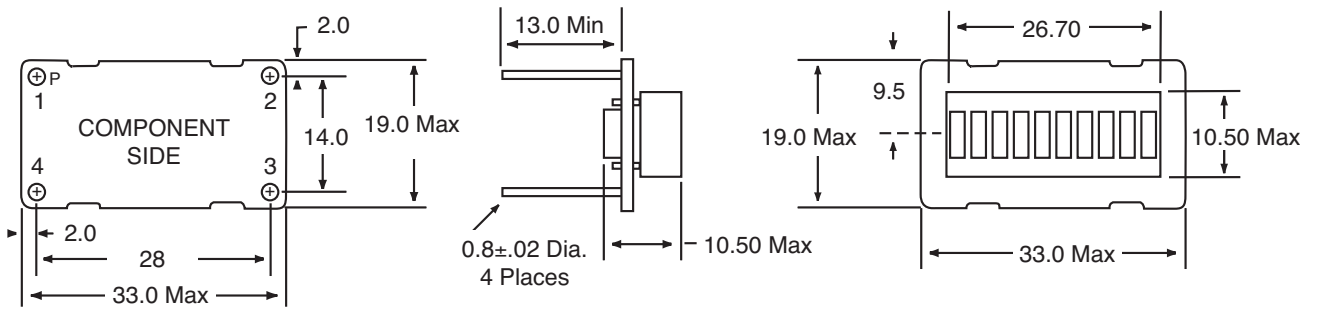

Case Style R

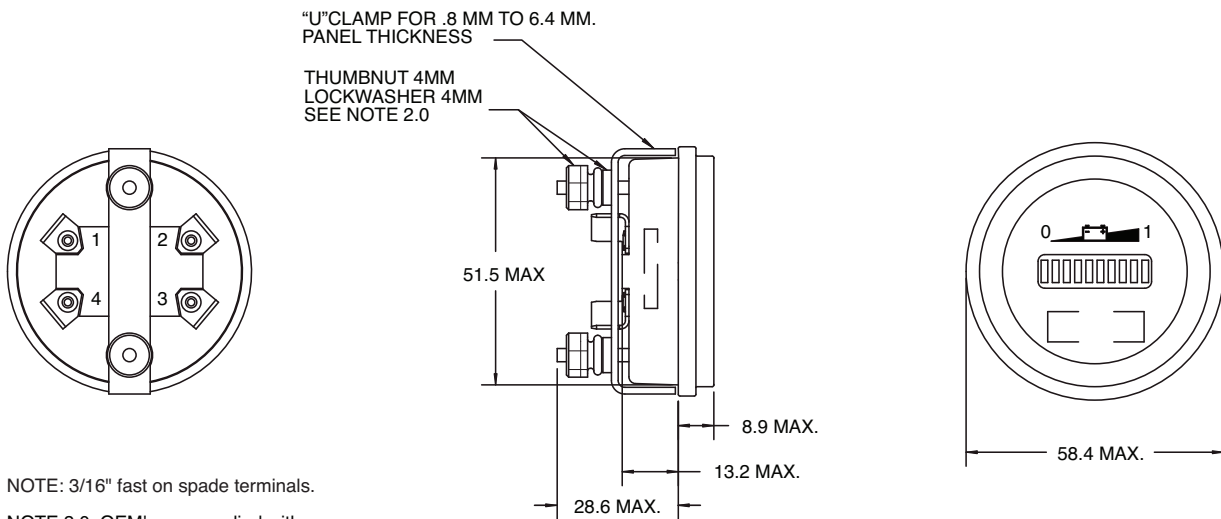

NOTE: 3/16" fast on spade terminals.

NOTE 2.0: OEM's are supplied with hex nuts and lock washers only. They do not receive thumbnuts.

PIN ASSIGNMENT

- 1 B+
- 2 B-
- 3 Output Signal + or No Option
- 4 Keyswitch +

MODEL 906

DIMENSIONS mm

Case Style T

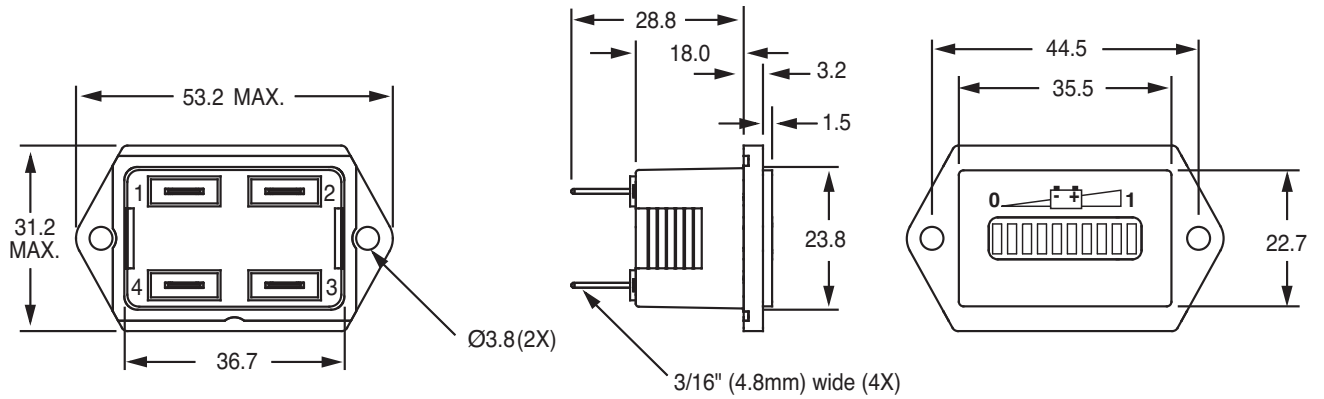

Case Style D

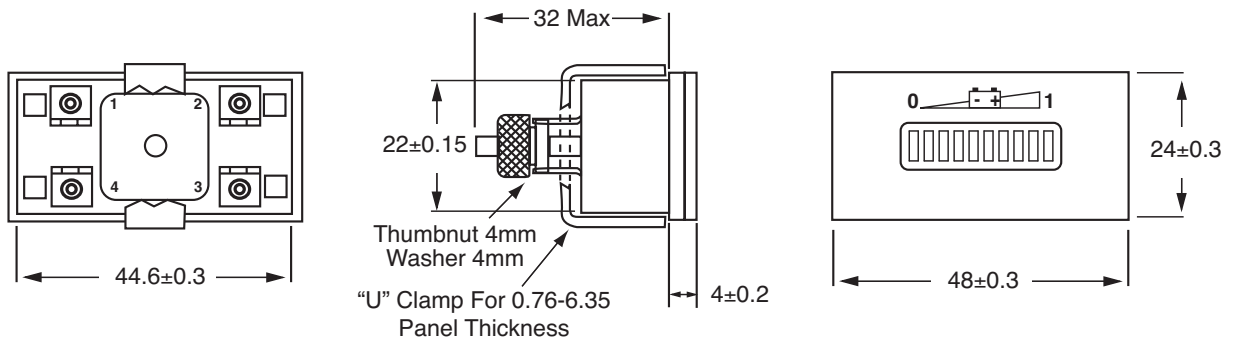

NOTE: $3/16''$ fast on spade terminals.

Case Style Y

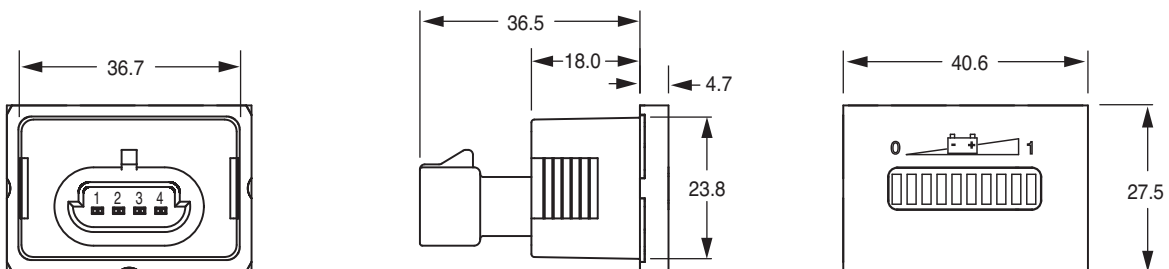

NOTE: Equivalent to Delphi-Packard connector P/N 15336035 4-pin.