

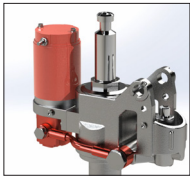

MJP-E-4400 Hybrid

Your Intelligent Warehouse Work Partner

How would MJP-E-4400 bring you fortune?



Electric Lifting Mode, easy and efficient

Hybrid Pump



Manual Lifting Mode, extending 30 minutes of working time
NO DOWNTIME

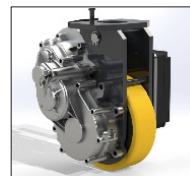

Brushless motor, Higher efficiency and performance,
Free Maintenance

Hybrid Driving



Patented ClutchTechnology, Electric/Manual convertible
NO DOWNTIME

I-Touch Screen



2.5 inch screen, High Resolution, Smart Touch

TIME	1	Sec
TRIP	0	km
BATTERY	25.6	%
SPEED	3	km/h
WEIGH	300	kg
SETUP		

Digital display of mileage, Battery status, Adjustable driving speed, Approximate load weight

VNA MODE	ON	
PASSWORD	ON	
SLOPE	8	%
MAX. SPEED	3	km/h
FAULT CODE	1502	
MORE INFO		
HOMEPAGE		

Single touch for VNA mode, Password setting, Readable slope degree, Direct diagnose of fault

Lithium Battery



48V15Ah big capacity, portable, 2-3 hrs quick charge, **2000** cycles with **80%** residual capacity
Remove and replace battery in seconds

Reinforced Fork

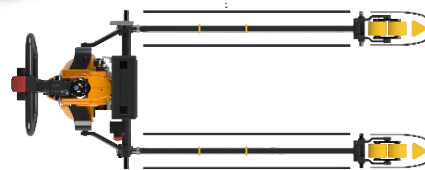

Super robust structure, Full loop enhancement

Specifications

MJP-E- 4400 Electric Pallet Truck Parameter and Performance

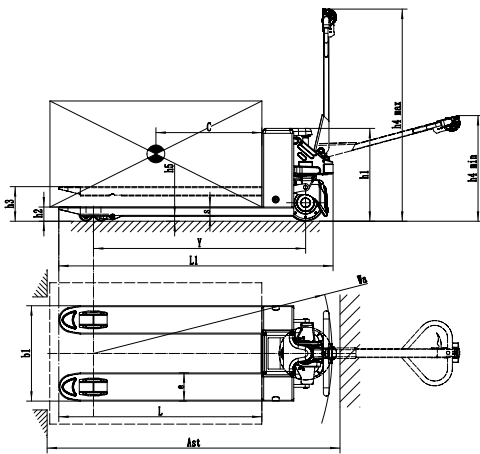

1	Manufacturer		Helmar Inc.
2	Model		MJP-E-4400
3	Drive		Electric / Manual
4	Lift		Electric / Manual
5	Operator type		Walkie
6	Load Capacity	Q	2000kg (4400lbs)
7	Load Center	C	600mm (24")
8	Wheelbase	Y	1202mm/1272mm (47.3"/50.1")
9	Service Weight		120/125kg (264/275lbs)
10	Overall Height	h1	587mm (23.1")
11	Fork Height (Lowered)	h2	80mm (3.15")
12	Lift Height	h3	200mm (8")
13	Tiller Arm Height	h4	560mm~1280mm (22"~50.4")
14	Ground Clearance	h5	27mm (1.1")
15	Overall Length	L1	1546mm/1616mm (60.8"/63.6")
16	Overall Width	b1	540mm/680mm (21"/27")
17	Fork Size	L	1150mm/1220mm (45"/48")
		S	53mm (2.1")
		e	160mm (6.3")
18	Turning Radius (Min.)	Wa	1352mm/1422mm (53.2"/56")
19	Aisle width for pallets 1000x1200 crossways	AST	1980mm (78")
20	Aisle width for pallets 800x1200 crossways	AST	1880mm (74")
21	Drive Motor		0.75kw Brushless
22	Travel Speed (laden/unladen)		4.5/4.8km/h (2.8/3.0mph)
23	Max. Gradeability (laden/unladen)	%	8%/20%
24	Brake Service		Electromagnetic
25	Lift Motor		0.65kw
26	Controller Manufacturer/Type		Curtis Instruments
27	Battery Voltage/Capacity V/Ah	V/Ah	48V/15Ah Lithium
28	Charger	A	48V/5A

Remarks: Helmar Incorporated reserves the right to make any changes without notice concerning specifications detailed in this brochure.

Highlights of MJP-E-4400:

- ▶ Extensible i-Touch system
- ▶ Electric/manual mode switch, **NO DOWNTIME**
- ▶ 8 hrs non-stop working with a spare battery
- ▶ Full load 8% gradeability, great performance
- ▶ Fork marks help easy positioning of 800mm/1000mm/1200mm pallets

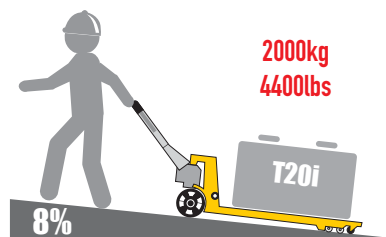
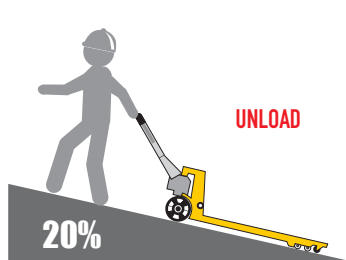

800mm /1000mm pallet marker



DURABILITY



ECO-PERFORMANCE



MAINTAINABILITY



PRODUCTIVITY